

COMPRESSOR DATA SHEET - COMPRESSOR DETAILS

Customer:	<input type="text"/>	Contact Name:	<input type="text"/>
Industry ¹⁾ :	<input type="text"/>	Plant code:	<input type="text"/>
Address:	<input type="text"/>	Telephone:	<input type="text"/>
Compl. By:	<input type="text"/>	Date:	<input type="text"/>

Make of Compressor:	<input type="text"/>	No of Compressors:	<input type="text"/>
Model:	<input type="text"/>	Serial No.:	<input type="text"/>
Gas Type:	<input type="text"/>	Please indicate Gas types if multi-service	If available, include gas analysis sheet

Speed [RPM]:	<input type="text"/>	Capacity [M ³ /hr / CFM]:	<input type="text"/>	Power [KW / HP]:	<input type="text"/>
Lubricated:	<input type="checkbox"/> Yes <input type="checkbox"/> No	Frame type:	<input type="checkbox"/> Vert. <input type="checkbox"/> Horiz <input type="checkbox"/> Vee <input type="checkbox"/> Tandem <input type="checkbox"/> L shape <input type="checkbox"/> other _____		

STAGE									
No. of Cylinders:									
Double / Single acting: [DA / SA]									
Stroke: [mm / in]									
Piston material [Al / CI / Steel]									
Piston weight [Kg / Lb]									
Cylinder Diameter: [mm / in]									
Cylinder Cooling: [water / air]									
Cyl liner material:									
Cyl chrome coated: [Yes / No]									
Clearance volume [HE / CE %]									
Amount of Valves per Stage									
Piston rod diameter ²⁾ : [mm / in]									
Piston rod material:									
Piston rod weight: [Kg / Lb]									
Piston rod coating:									
Rod surface finish μ [mm / in]									
Suction pressure ³⁾ : [bar / psi]									
Suction Temp. [°C / °F]									
Disch. pressure ³⁾ : [bar / psi]									
Discharge Temp. [°C / °F]									

Other general information:
History of operation, ring life, failures etc.

1) e.g. Refinery, Oil/Gas production, Ind. Gases, Cement plant, Fertiliser, Brewery, Sewage works, Power station, Sugar mill etc.
 2) Critical dimension, required accuracy is +/- 0.025 mm
 3) Pressures are in gauge (ie barg / psig) absolute (ie bar / psi)

COMPRESSOR DATA SHEET - PACKING CASE DETAILS

BOX BORE DETAILS

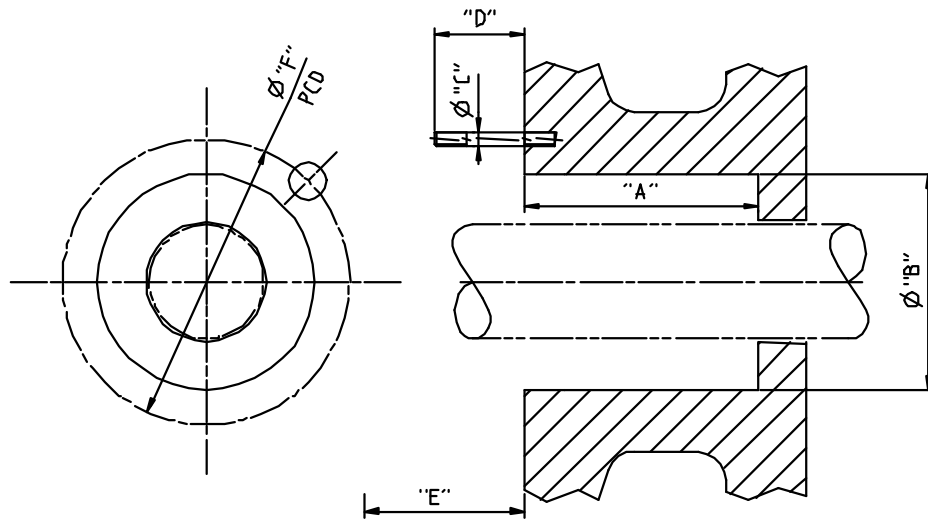

- A= Stuffing box depth
- B= Stuffing box bore
- C= Number of studs
- ϕ = Stud diameter
Indicate top & position of first stud
- D= Stud length
- E= Clearance between face of pkg case and nearest obstruction
- F= PCD of studs
Indicate top and position of first stud hole

Please advise if there are any existing tappings into the stuffing box bore

Does the box bore have external cooling? Yes No

PACKING CASE DETAILS

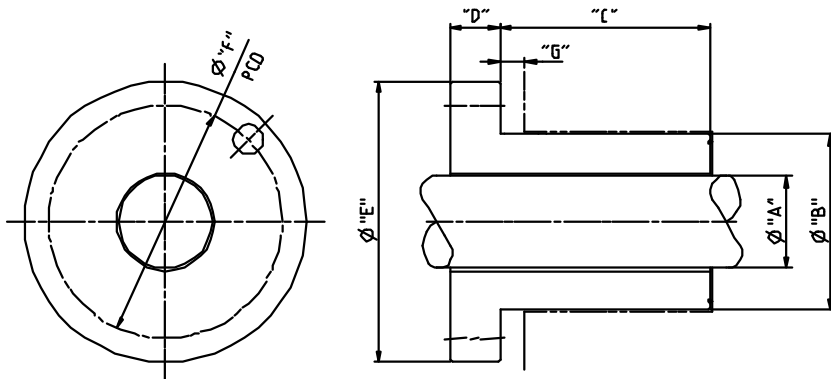

- A= Rod diameter
- Rod surface finish
- B= Case OD
- C= Case length
- D= Flange width
- E= Flange diameter
- F= PCD of stud holes
- Allowable flange stand-out

- Does the box bore have external cooling? Yes No
- Is the packing case cooled? Yes No
- Indicate the location of the Vent, Lube, Purge and Cooling and the flange drawing
- Indicate top and position of first stud hole

Type of packing case: (Main, intermediate, Oil)

Packing case material:

Maker's P/N of packing case?

SERVICE TAPPING SIZES

- Vent Type ?
- Lube Type ?
- Purge Type ?
- Coolant Type ?

CUP DETAILS

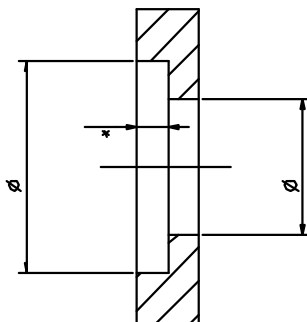

- Pressure breaker NO. OF GROOVES
- Main sealing ring
- Vent ring
- Makers P/N of existing packings

* Critical information, required accuracy is +/- 0.025 mm (0.001")

COMPRESSOR DATA SHEET - PACKING RING DETAILS

Rod Dia:

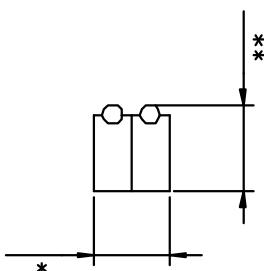

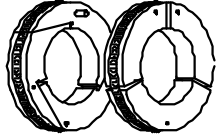
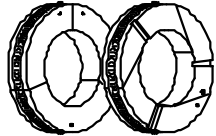
P20

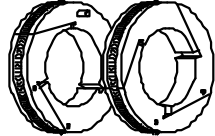
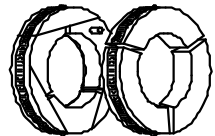
 P24 / P25 ¹⁾

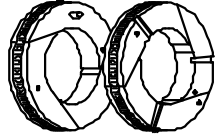
P21

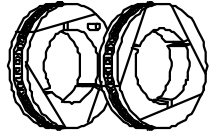
 P26 / P27 ¹⁾

P22

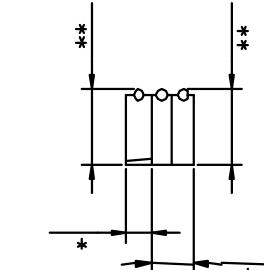
 Other (Sketch)

P23

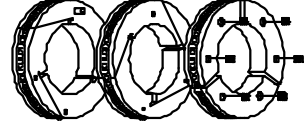
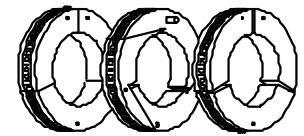
Rod Dia:

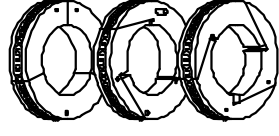
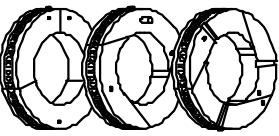

P30 / P31 ¹⁾

 P34 / P35 ¹⁾

P32 / P33 ¹⁾

 P36 / P37 ¹⁾

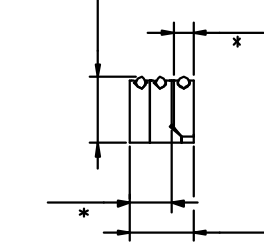
Other (Sketch)

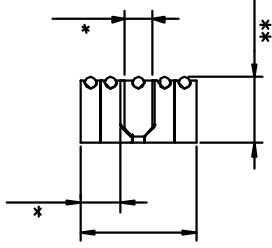
Rod Dia:

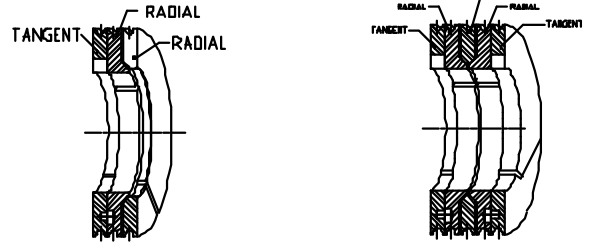

P38

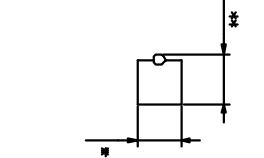

P51

Rod Dia:

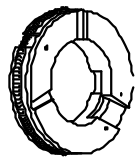

P11

P12

P13

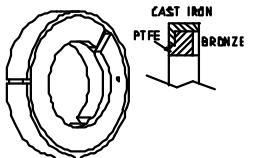
P14

Rod Dia:

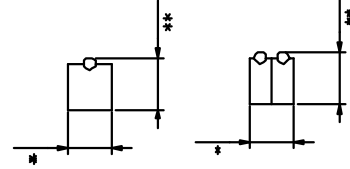

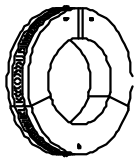
P15

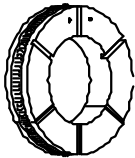
P16 / P17 ¹⁾

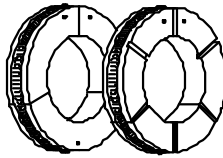
P28 / P29 ¹⁾

Other (Sketch)

Seal Type	Qty	Materials: Sealing rings	Materials: Backup rings

* Critical dimension, required accuracy is +/- 0.025mm

** Largest measured radial ring thickness over spring

¹⁾ This P/N with a solid backup ring

Dimensions in mm in

COMPRESSOR DATA SHEET - P/R & R/R DETAILS

Cylinder dia. Note – this is a critical dimension, accuracy required is +/- 0.25 mm

No. of Piston rings: (per piston) Material:

<input type="checkbox"/> Without expander	<input type="checkbox"/> Twin ring	<input type="checkbox"/> With expander	<input type="checkbox"/> Pressure balanced	<input type="checkbox"/> Other (Sketch)
---	------------------------------------	--	--	---

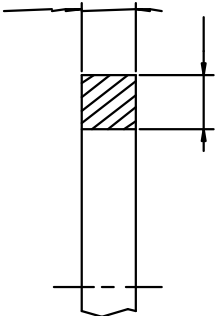
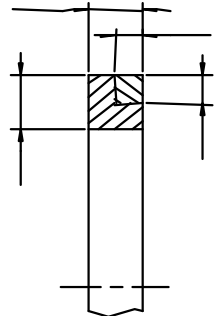
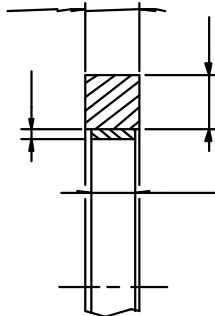
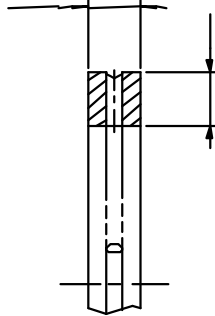
# of segments per ring <input type="text"/>	# of segments per ring <input type="text"/>	# of segments per ring <input type="text"/>	# of segments per ring <input type="text"/>	# of segments per ring <input type="text"/>
--	--	--	--	--

<input type="checkbox"/> Angle cut	<input type="checkbox"/> Straight cut	<input type="checkbox"/> Step cut	<input type="checkbox"/> Other (Sketch)
------------------------------------	---------------------------------------	-----------------------------------	---

No. of Rider rings: (per piston) Material:

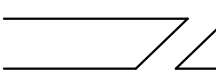
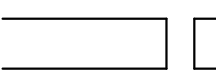
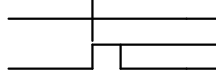
<input type="checkbox"/> Angle cut ¹⁾ & pressure relieved, OD & edges	<input type="checkbox"/> Angle cut ¹⁾ & pressure relieved, edges only	<input type="checkbox"/> 2 pieces (halves) & pressure relieved (as shown)	<input type="checkbox"/> Uncut / solid
--	--	---	--

* Critical dimension, required accuracy is +/- 0.025 mm ** Critical dimension, required accuracy is +/- 0.025 mm

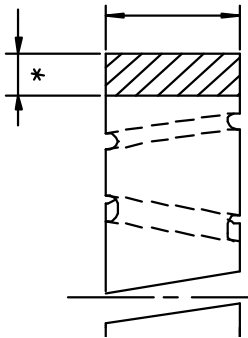
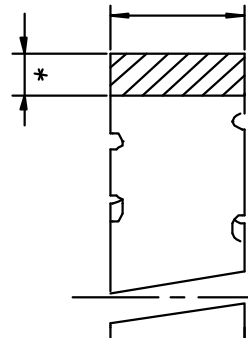
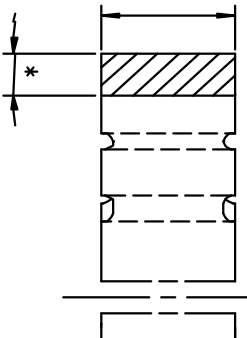
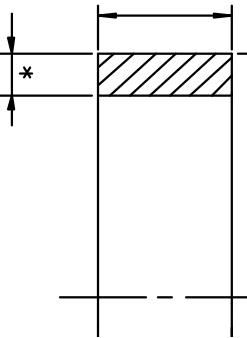
PISTON DETAILS

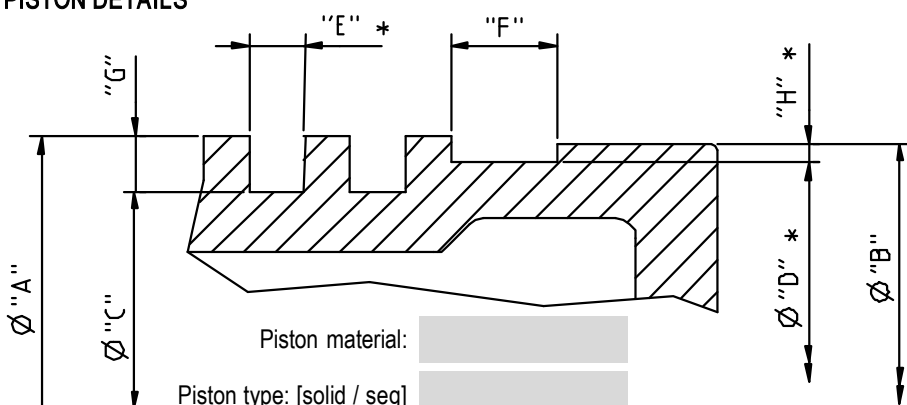

A=	<input type="text"/>	Piston OD
B=	<input type="text"/>	Slip over Ø
C=	<input type="text"/>	Piston ring groove Ø
D=	<input type="text"/>	Rider ring groove Ø
E=	<input type="text"/>	Piston ring AGW
F=	<input type="text"/>	Rider ring AGW
G=	<input type="text"/>	Piston ring groove depth
H=	<input type="text"/>	Rider ring groove depth

Piston material:

Piston type: [solid / seg]

Piston weight: [Kg / Lb]

* LEAH standard for rider rings = 10° Dimensions in mm in

COMPRESSOR DATA SHEET - SCRAPER RING DETAILS

Rod Dia:

W11 W12 Other (Sketch)

W14 W15

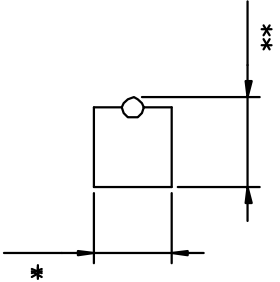
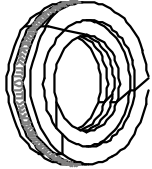
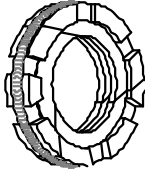
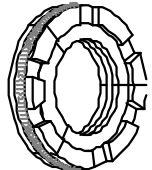
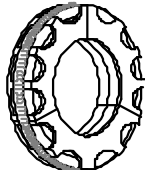
Rod Dia:

W20 Other (Sketch)



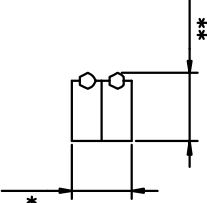
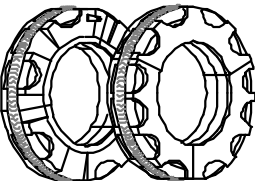

Rod Dia:

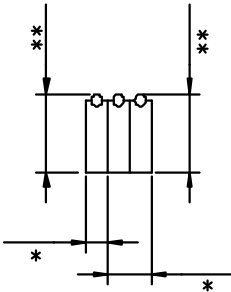
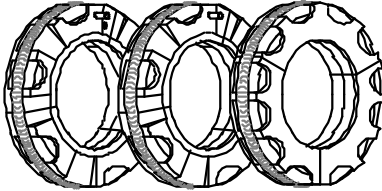
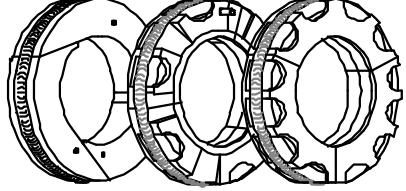
W30 W31

CUP DETAILS

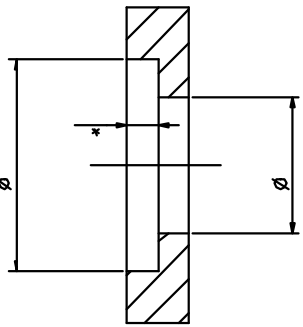

Number of grooves

Types of existing Oil scraper rings

Types of existing pulsation rings
eg. P11, P21, P30/P31 (refer to packing ring data sheet)

Makers P/N of existing rings

Type	Qty	Materials:	Oil scraper rings	Materials:	Pulsation seals

* Critical dimension, required accuracy is +/- 0.025 mm

** Critical dimension, required accuracy is +/- 0.10 mm

